

4

3

2

1

PART NO. CA-XXIDS3-X-XXX-SR

REVISIONS				
LTR	DESCRIPTION	DATE	APPROVED	
A	INITIAL RELEASE SEE DO 5756	CP 04-26-05	L.F.	
B	SEE DO 5761	CP 04-28-05	L.F.	
C	SEE DO 6218	CP 09-25-06	I.M.	
D	SEE DO 7447	CP 03-06-18	T.H.	
E	SEE DO 7524	CP 05-28-19	T.L.	
F	SEE DO 7567	CP 04-27-20	T.L.	
G	SEE DO 7593	CP 12-10-20	T.L.	

D

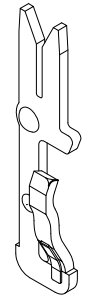
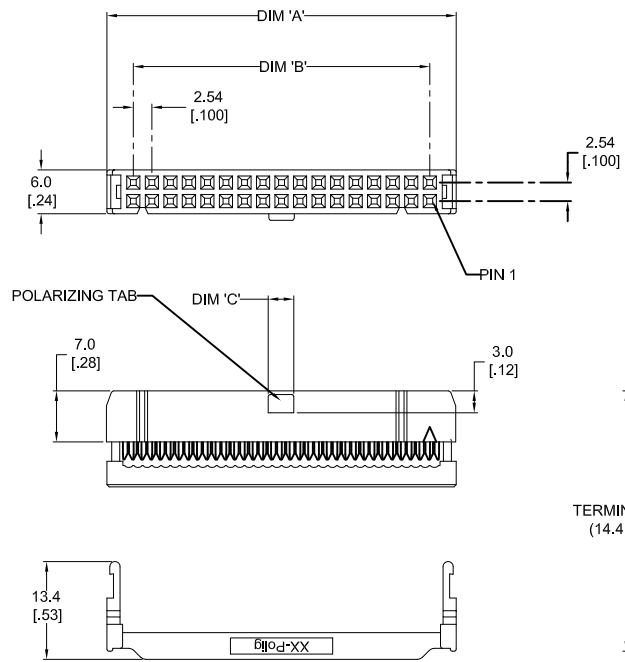

CA-XXIDS3-X-XXX-SR

NO OF POSITIONS

IDC SOCKET, IDS3 SERIES

PLATING

C = .00038 [.000015] GOLD IN CONTACT AREA
.000254 [.00100] TIN IN IDC AREA
.000100 [.00040] NICKEL UNDERPLATE

F = .00076 [.000030] GOLD IN CONTACT AREA
.000254 [.00100] TIN IN IDC AREA
.000100 [.00040] NICKEL UNDERPLATE

POLARIZATION

SPT = WITH POLARIZING TAB
BLANK = WITHOUT POLARIZING TAB

STRAIN RELIEF

C

D

TABULATION :

NO. OF POSITION	DIM 'A'		DIM 'B'		DIM 'C'	
	MM	INCH	MM	INCH	MM	INCH
6	12.32	0.485	5.08	0.200	1.85	0.073
8	14.86	0.585	7.62	0.300	1.85	0.073
10	17.40	0.685	10.16	0.400	3.50	0.138
12	19.94	0.785	12.70	0.500	3.50	0.138
14	22.48	0.885	15.24	0.600	3.50	0.138
16	25.02	0.985	17.78	0.700	3.50	0.138
20	30.10	1.185	22.86	0.900	3.50	0.138
24	35.18	1.385	27.94	1.100	3.50	0.138
26	37.72	1.485	30.48	1.200	3.50	0.138
30	42.80	1.685	35.56	1.400	3.50	0.138
34	47.88	1.885	40.64	1.600	3.50	0.138
36	50.42	1.985	43.18	1.700	3.50	0.138
40	55.50	2.185	48.26	1.900	3.50	0.138
44	60.58	2.385	53.34	2.100	3.50	0.138
50	68.20	2.685	60.96	2.400	3.50	0.138
56	75.82	2.985	68.58	2.700	3.50	0.138
60	80.90	3.185	73.66	2.900	3.50	0.138
62	83.44	3.285	76.20	3.000	3.50	0.138
64	85.98	3.385	78.74	3.100	3.50	0.138

B

A

3. MEETS THE REQUIREMENTS OF THE EUROPEAN PARLIAMENT AND THE RESTRICTION OF THE USE OF CERTAIN HAZARDOUS SUBSTANCES IN ELECTRICAL AND ELECTRONIC EQUIPMENT. (RoHS)

2. SPECIFICATIONS :

MATERIAL :
INSULATOR : PBT, GLASS REINFORCED, COLOR GRAY, UL94V-0
CONTACT : PHOSPHOR BRONZE OR BRASS
PLATING : SEE ORDERING NOMENCLATURE

ELECTRICAL :
CURRENT RATING : 1 AMP
CONTACT RESISTANCE : 30 MILLIOHMS MAX.
INSULATION RESISTANCE : 3000 MEGOHMS MIN.
DIELECTRIC WITHSTANDING VOLTAGE : 500 VAC FOR 1 MINUTE
OPERATING TEMPERATURE : -40°C TO +105°C

1. TERMINATED WITH 1.27mm [.050] PITCH FLAT RIBBON CABLE.

NOTES: UNLESS OTHERWISE SPECIFIED

DIMENSIONS ARE IN MILLIMETER TOLERANCES ARE:		APPROVALS	DATE	CIRCUIT ASSEMBLY CORP. 6 AUTRY SUITE 150, CALIFORNIA 92618 CONNECTOR ASSEMBLY-IDS3 SERIES "RoHS"
DECIMALS	ANGLES	DRAWN	4-26-05	
X 2.30	?#P.XX ? 20	CHECKED	4-26-05	SIZE CODE IDENT NO. DRAWING NO. REV. C 52072 610317 G
DIMENSIONS IN BRACKETS (X.XX) ARE INCHES TOLERANCES ARE:		THE INFORMATION AND DESIGN DISCLOSED HEREIN WAS ORIGINATED BY AND IS THE PROPERTY OF CIRCUIT ASSEMBLY CORPORATION. "CIRCUIT ASSEMBLY CORPORATION RESERVES ALL PATENT, PROPRIETARY, DESIGN, MANUFACTURING, REPRODUCTION, USE AND SALES RIGHTS THEREIN. AND TO ANY ARTICLE DISCLOSED HEREIN EXCEPT TO THE EXTENT RIGHTS ARE EXPRESSLY GRANTED TO OTHERS. THE FOREGOING DOES NOT APPLY TO VENDOR PROPRIETARY RIGHTS.		SCALE: 2:1 SHEET 1 OF 1
DO NOT SCALE DRAWING				

4

3

2

1



D

C

D

B

A